

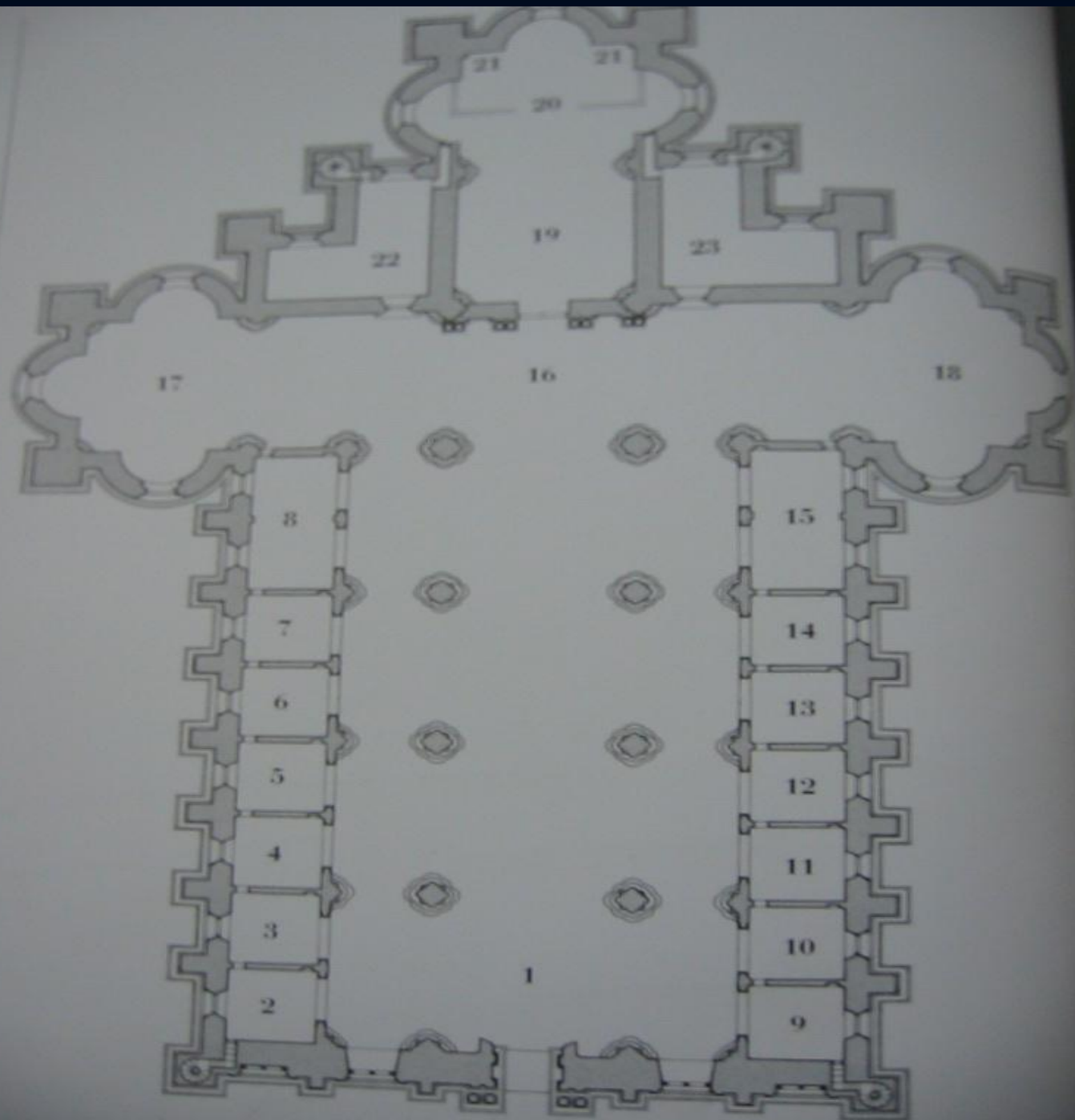

# LA CERTOSA DI PAVIA

Uni-A.T.E.NeO

2011



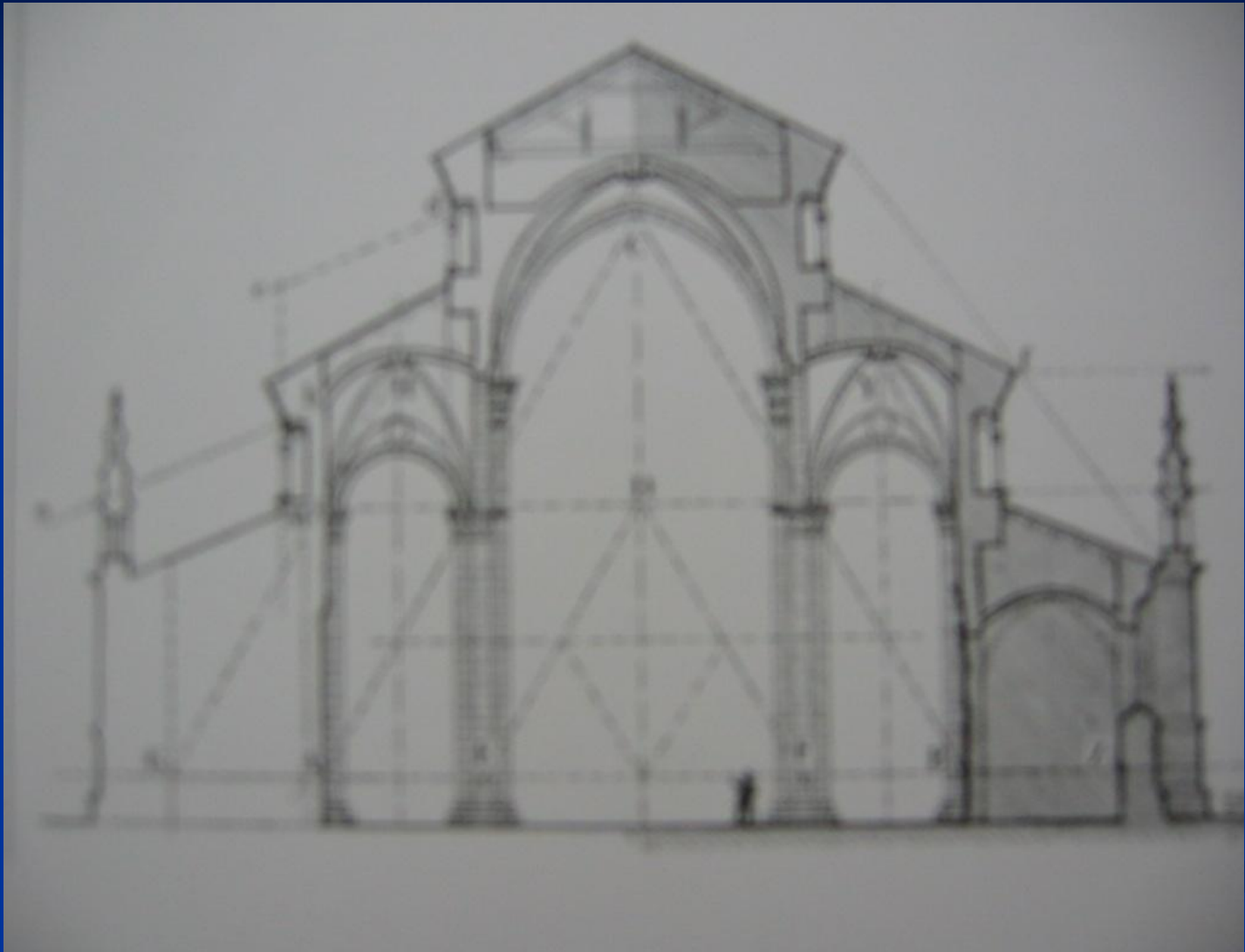

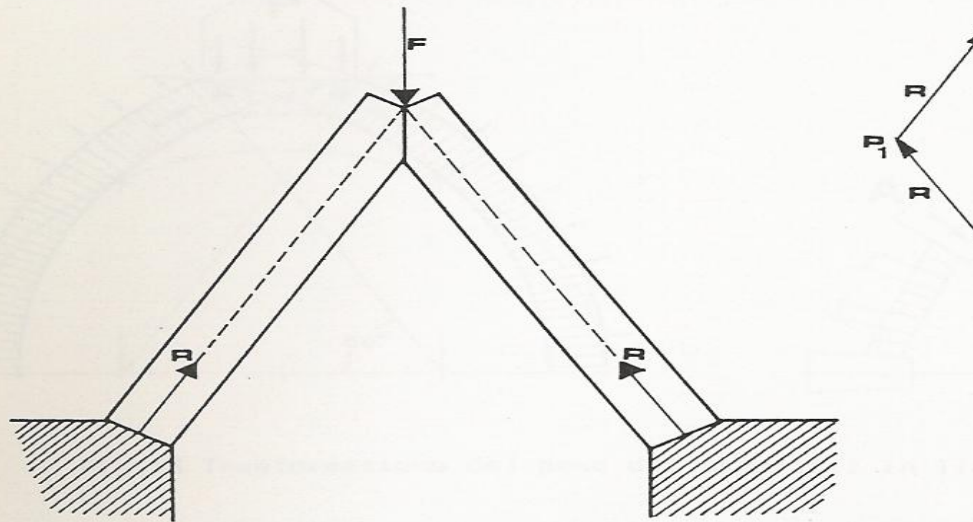

Fig.11 Portale primitivo costituito da due lastre.

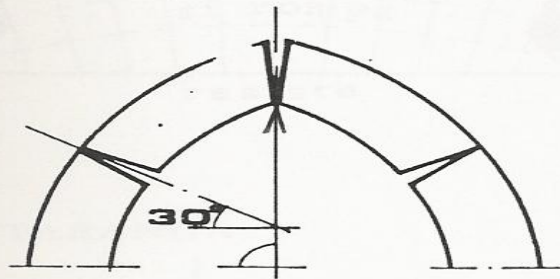
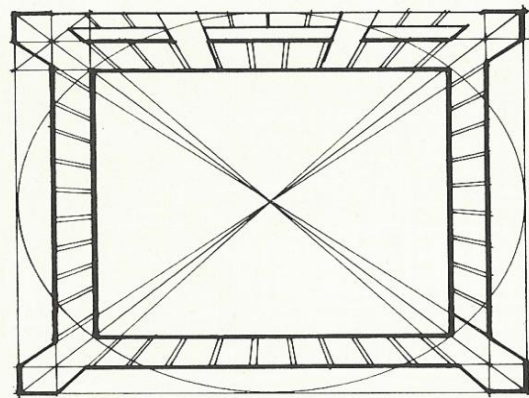
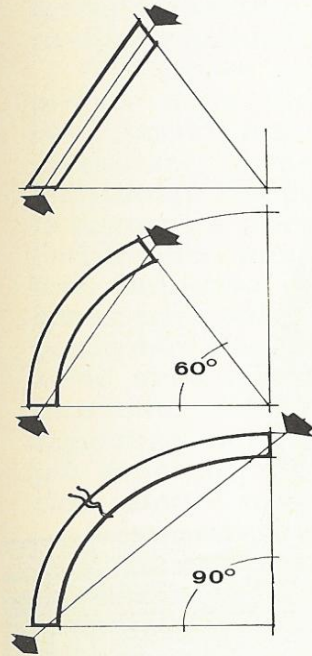
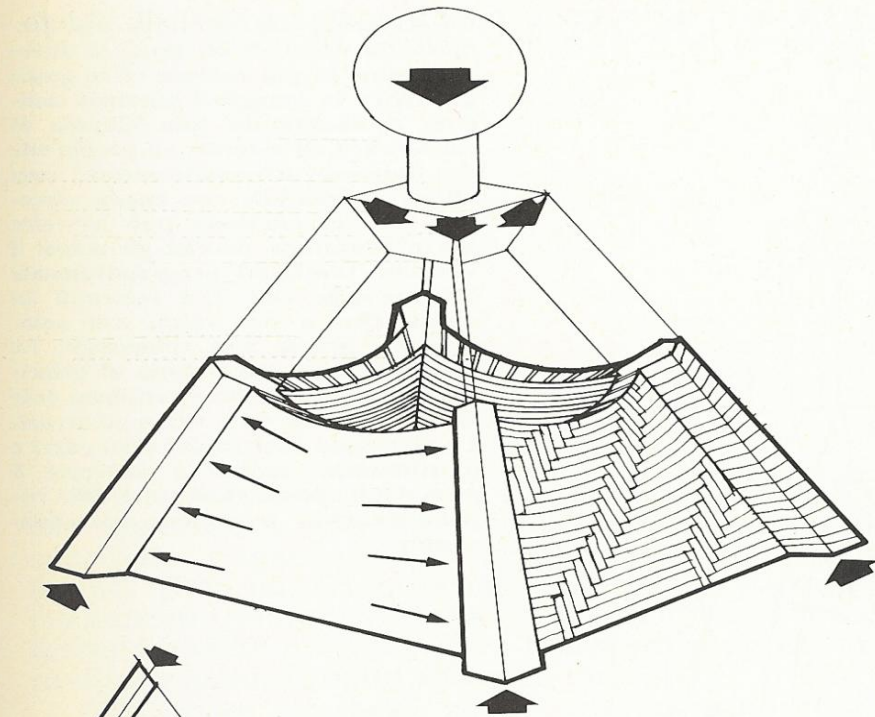

Fig.12 Apertura di lesioni in arco a sesto acuto.





PAROVI

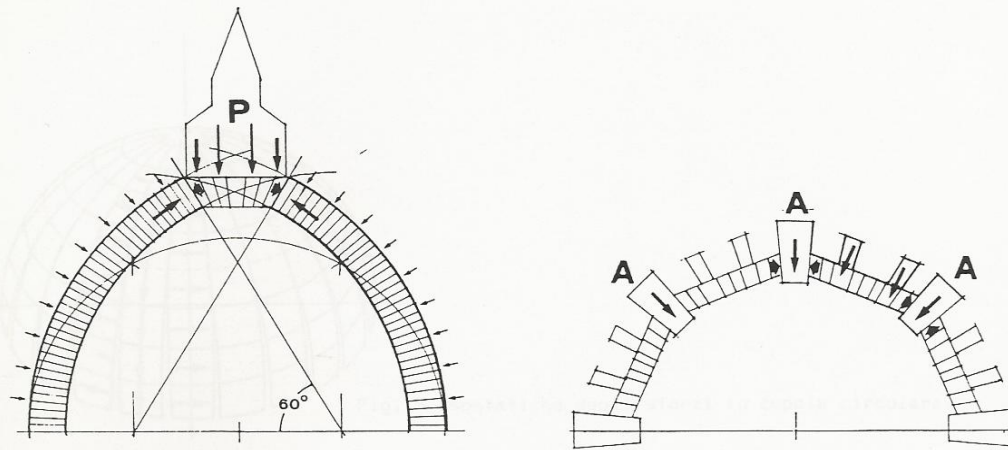
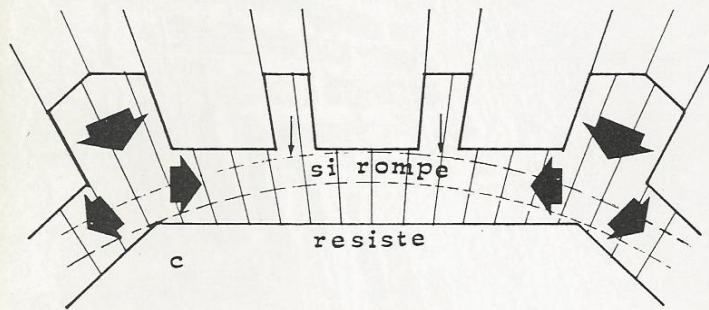
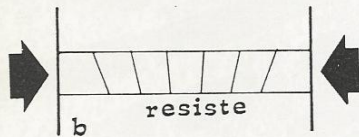

Fig.13 Trasformazione del peso dei materiali in linee di forza.



LA PIATTABANDA



L'ARCO



Fig.14 Funzionamento della piattabanda.

































































# ■ LA CHIESA



















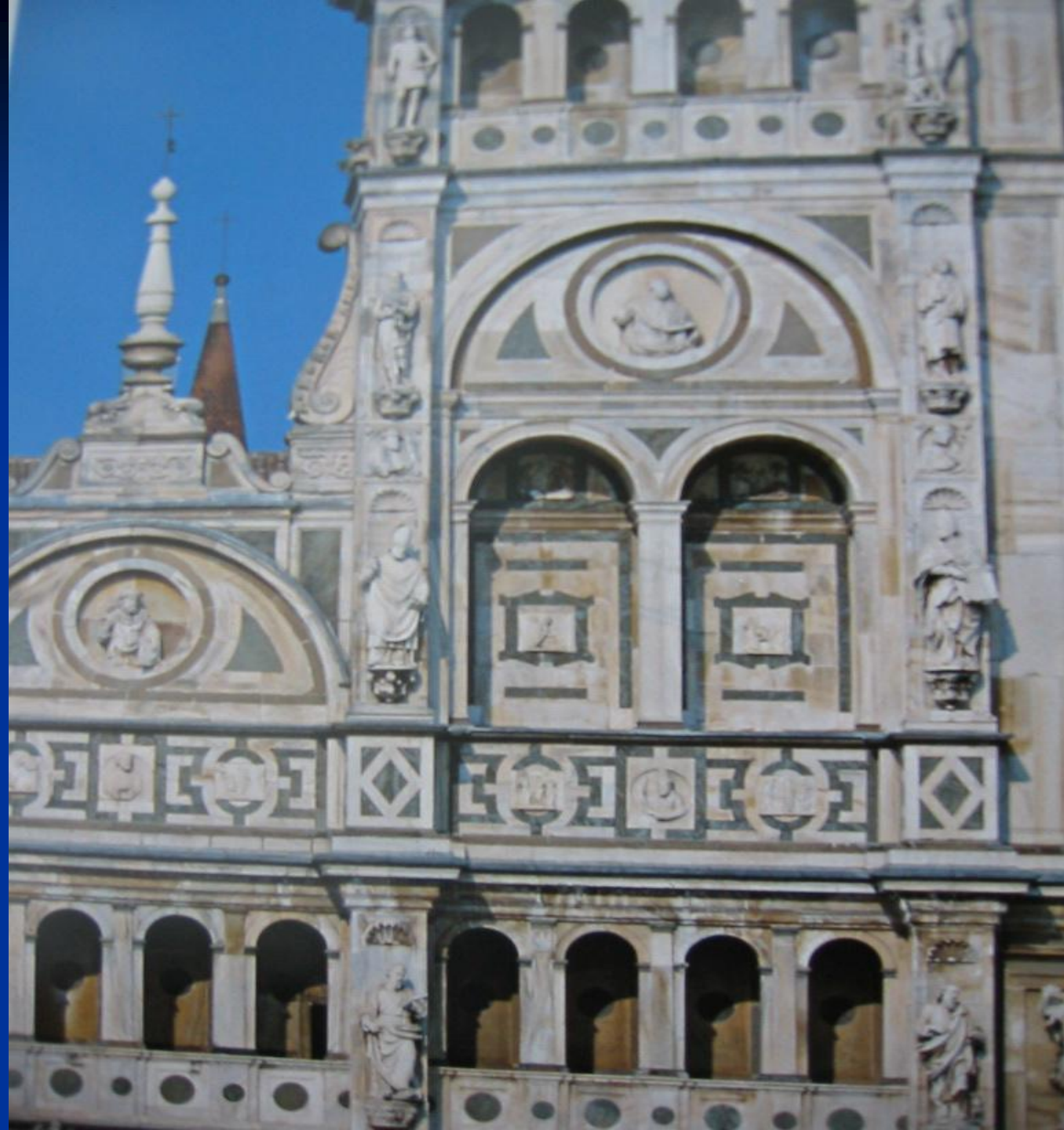































- NAVATA CENTRALE E NAVATE LATERALI
  - CAPPELLE



































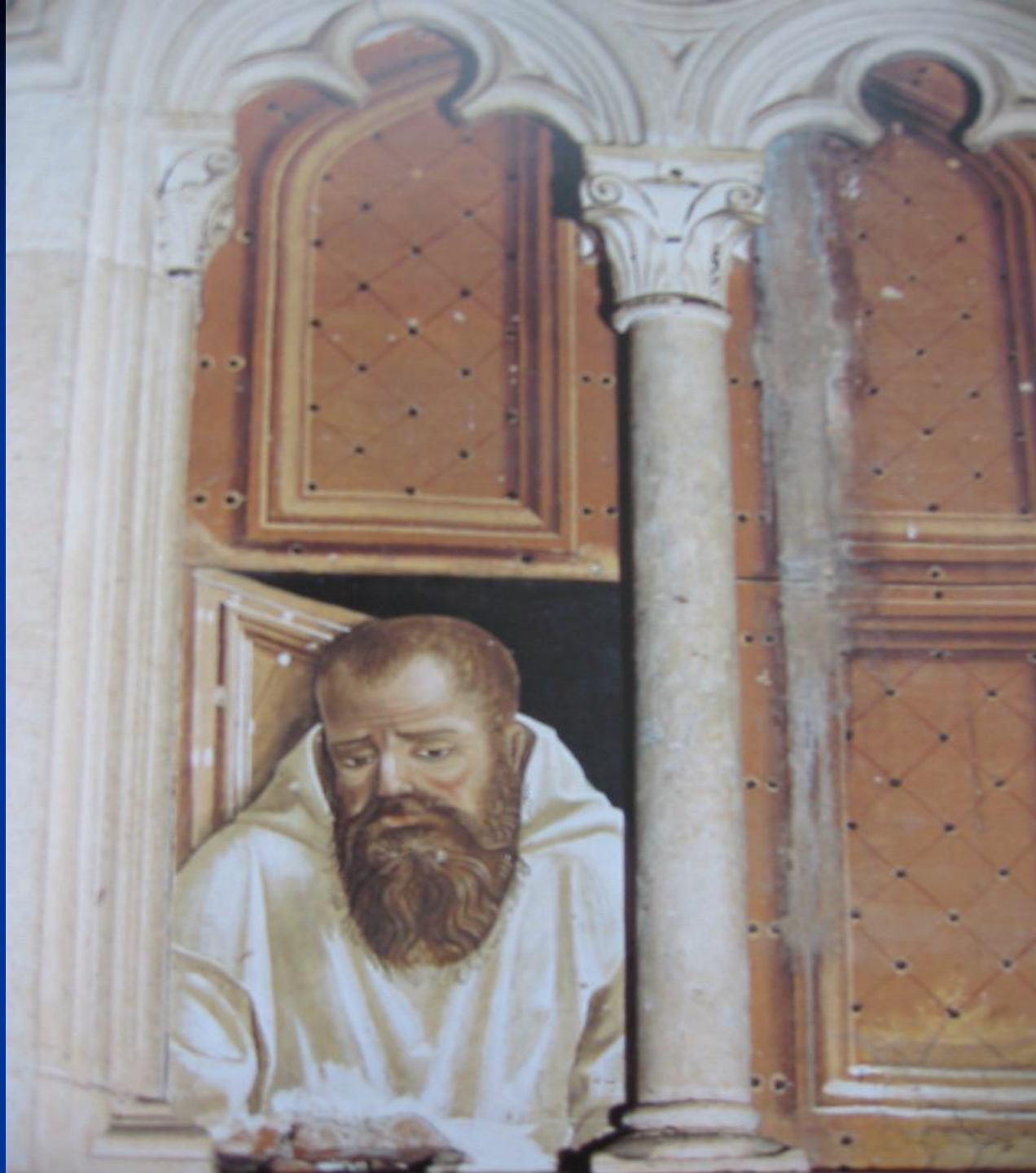

























































# ■ TRANSETTO























# ■ CORO E PRESBITERIO









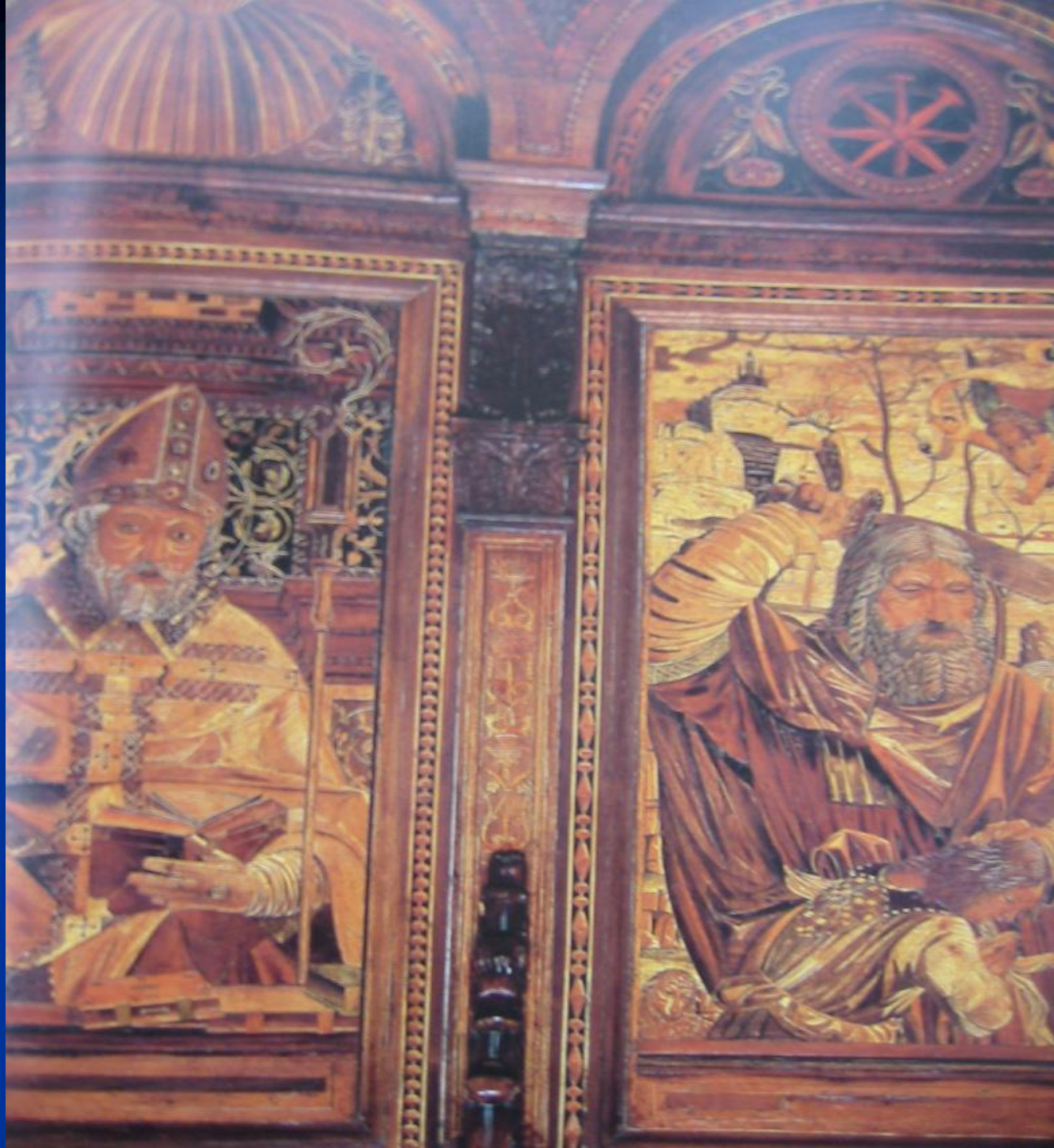





































- CHIOSTRO PICCOLO
  - SACRESTIA NUOVA
    - BIBLIOTECA
    - REFETTORIO
- CHIOSTRO GRANDE







